

SACKSAFOAM™ III

FIREFIGHTING FOAM INJECTION SYSTEM FOR THE BAMBI BUCKET®

The Sacksafoam™ III is designed to be used in medium and heavy lift helicopters in combination with the large series of Bambi Bucket®s (models 5566HD to HL9800). The SF III is identical to the SF II model 5598, with the exception of the control unit, which is built into the lid of the case. The operation of the system is performed by a member of the crew other than the pilot or copilot.



TOP FEATURES

- Self-contained foam injection system mounted onboard the helicopter.
- Eliminates any potential for spillage from the pouring of foam concentrate.
- Allows for a multitude of nonstop cycles.

UNIT EASILY INSTALLED AND REMOVED

DURABLE CASE

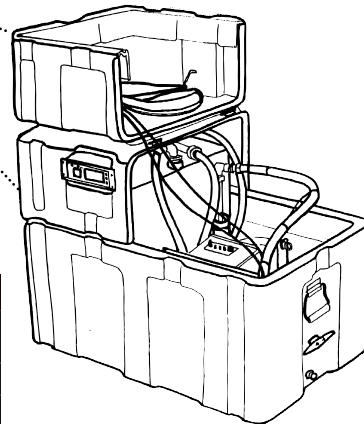

USER-FRIENDLY FUNCTION CONTROLS

SACKSAFOAM™ III DIMENSIONS

Model	Length		Width		Height	
	in	cm	in	cm	in	cm
SFF03-8044	33	84	21	53	26	66

SACKSAFOAM™ III SPECIFICATIONS

Model	For Bambi Bucket®	Foam Concentrate Capacity		Empty Weight		Full Weight	
		USG	Liters	Lbs	Kg	Lbs	Kg
SFF03-8044	BB5566 to BB1821	25	94	59	27	139	63

WATER/FOAM PROOF CASING INCLUDES

- A 20 USG (76 L) foam concentrate tank.
- Extra stowage area for a 5 USG (19 L) reserve tank.
- Fill and discharge pump (runs on helicopter's 28V DC power).
- Pumping and discharging control unit built into lid.
- Wiring for connection to heli power & remote dump switch for Bambi Bucket® (28V DC power).
- 6 ft. (1.8 m) foam delivery hose with breakaway end.

COMPATIBLE WITH

- Bambi Bucket® models BB5566 to HL9800
- Torrentula® Bucket models BBT5566 to BBTHL9800

